

STAND OUT
Inspiration til dit business event

WIND ENERGY 2022 HAMBURG
27.09.2022 – 30.09.2022



✓ RÅDGIVNING
✓ DESIGN
✓ HÅNDVÆRK
✓ TEKNOLOGI

STANDESIGN

STANDESIGN PROJECT MANAGER



Birger Gaard
Project Manager
E-mail: birger@standesign.dk
Phone: +45 20 40 79 66



FURNITURE INCLUDED IN YOUR FEE

- 1 x Table (low or tall)
- 3 x Chairs or bar chairs
- 1 x Brochure stand
- 1 x 220V with approx 300 W for charging phone, laptop etc



EXPO POSTERS

Recommended when:

- Monitor is incorporated in wall
- Graphics contain many small details

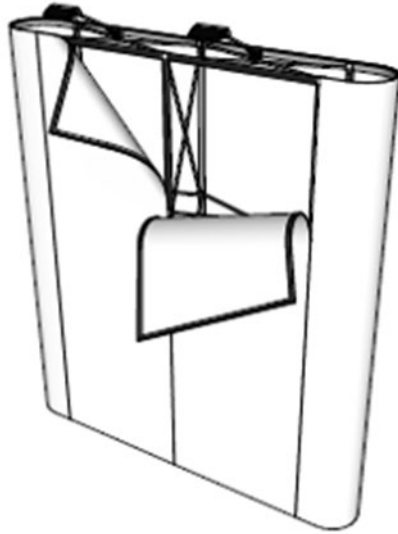

EXPO POSTERS - BACKLIT

Recommended when:

- Graphics have many contrasting colors
- Highlighting certain details

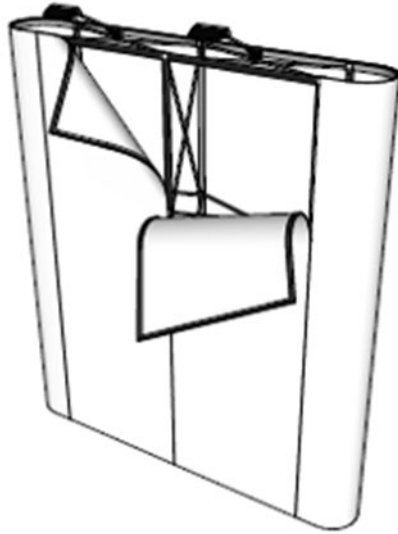

GRAPHICS FOR YOUR BOOTH

Specifications for your print files:

Graphics dimensions:

- 1 poster: w: 780 x h: 2367mm
 - 2 posters: w: 1560 x h: 2367mm
 - 3 posters: w: 2340 x h: 2367mm
 - 4 posters: w: 3120 x h: 2367mm
-
- Add 10 mm bleed (crop marks must be visible)
 - All text must be outlined
 - All images must be minimum 100 dpi
 - All logos in EPS or AI file
 - All colors will be printed in CMYK
-
- Print ready pdf's must be sent by www.wetransfer.dk to the project manager

Standesign offers to produce the printing file.
Please order DTP in the order form



MONITOR ON EXPO WALL WITH 1 POSTER

- Monitors can be mounted on front (32", 42", 50" and 55")
- Can only be placed at vertical center of the poster

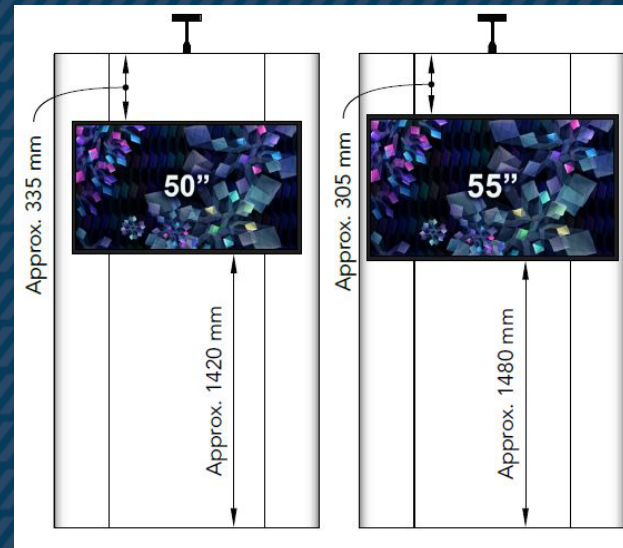
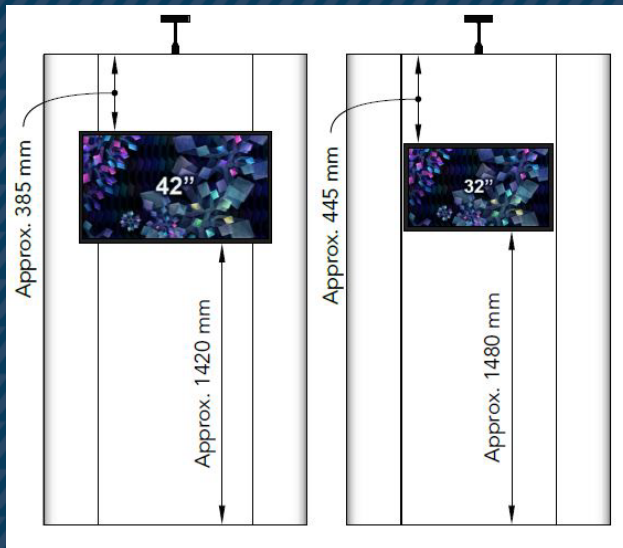

MONITOR ON EXPO WALL WITH 2 POSTERS

- Monitors can be mounted on front (32", 42", 50" and 55")
- Can only be placed at vertical center of each poster

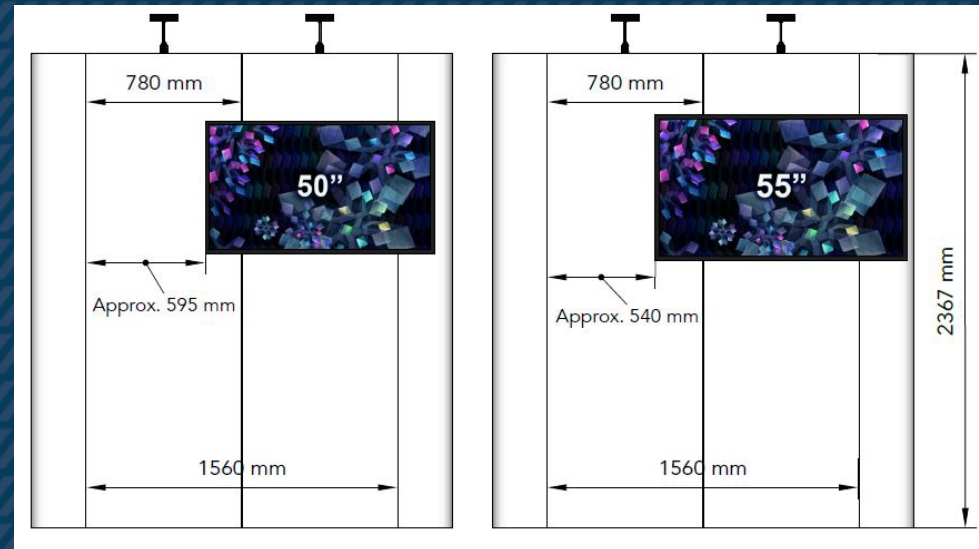
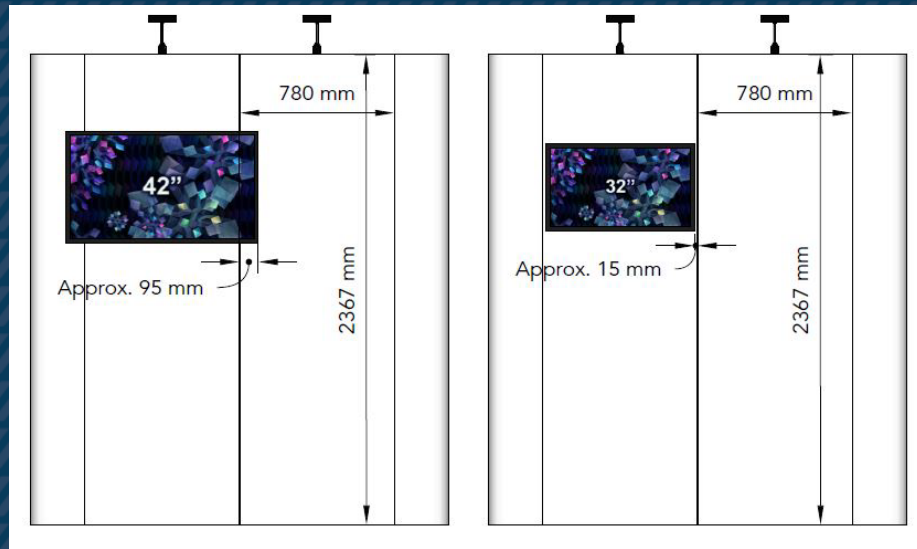

MONITOR ON EXPO WALL WITH 2 POSTERS – MID-POSITION

- Monitors can be mounted on front (50", 55", 60" and 65")
- Can with special equipment be placed at the center of the EXPO wall

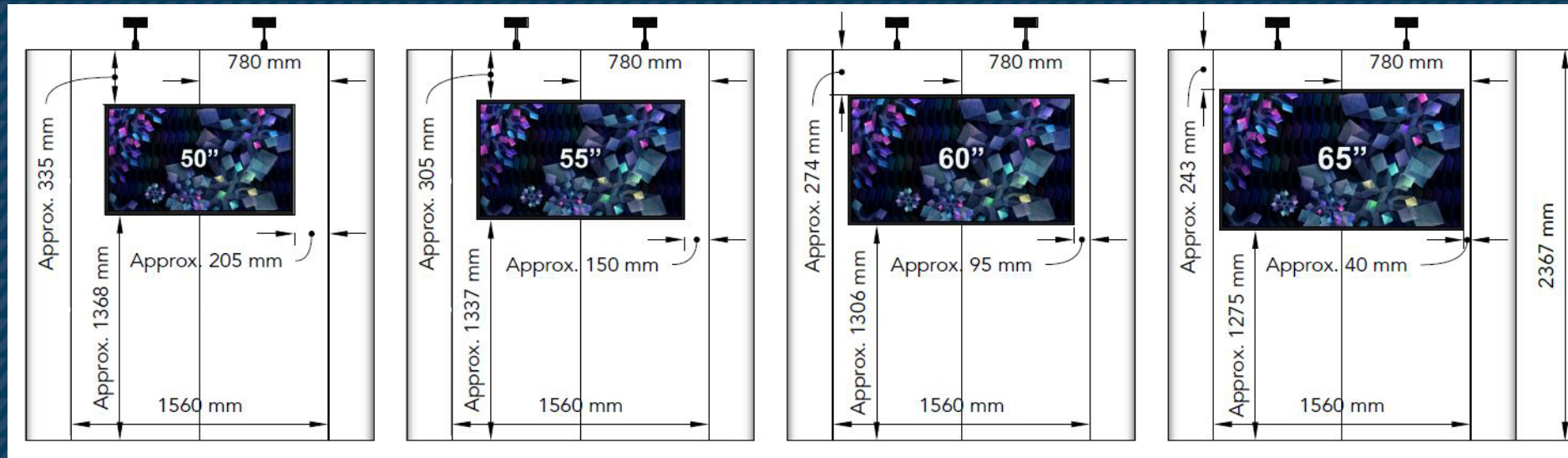

ORDER FORM

- Please fill out the order form and return by email to: birger@standesign.dk
- Deadline: 27th of August 2022
- End curves will have text. Company name or web address in same size and font. Remember to indicate the required text for your end curves in the order form



HANDLING OF YOUR GOODS

Standesign can help you handling your own equipment (unpacking and packing)

Must be ordered in advance via the order form

Please indicate estimated hours and provide the following information:

- Arrival of the goods
- Amount of crates

Please note: We only empty the crates. We do not assemble your equipment



STAND HANDOVER

- Stand handover:
26th of September 2022 between 14.00 -16.30

Stands must be completed, and excess products and materials must be removed from all halls no later than 17:30 on Monday 26th of September – please allow time to load and unload vehicles.

During build up and breakdown, contractors and exhibitors are required to wear build up/breakdown passes and Personal Protective Equipment at all times and to comply with the Health and Safety regulations of the venue



STAND OUT

Inspiration til dit business event

-  RÅDGIVNING
-  DESIGN
-  HÅNDVÆRK
-  TEKNOLOGI